



115 Volt ACE® Remote Light Source with EKE lamp, A20560



10' Extension Cord with CPC connectors, A29505

ACE® Remote Power Supply <small>Modulamp®/lamp not included</small>	
A20560.115	115 V Power Supply Only
Extension Cord	
A29505	10' extension - CE and CSA Comp.

EKE, DDL, and EJA lamps and Modulamp® units can be purchased separately.

ACE® Remote Light Source

All the features of our universally accepted ACE® light source with the added convenience of the following:

Remote Features

- 6' shielded black cable provides remote intensity control, including ON/OFF.
- Positive locking, quick disconnect cable will not pull out.
- CSA approved to UL spec, CE compliant to low voltage and EMC directives.
- 10' shielded extension available as an option.
- Modulamp assembly purchased separately

Standard Features

- Heavy duty, grounded metal housing.
- 115 input voltage version available.
- IR interference filter for cool illumination.
- Full illumination on .60" active diameter input.
- Solid state dimmer control.
- Interchangeable Modulamp® Units offer 2 positions to maximize individual lamp efficiencies.
- Choice of three, 150 watt halogen lamps - EKE, EJA, and DDL for intense, uniform illumination.
- Built-in thermal shut down.
- Fan cooled.
- Zero to full intensity.
- Low housing temperature
- Detachable IEC cord.

Options

- Infinite setting, twelve blade iris diaphragm version available to reduce intensity while maintaining color temperature.

Power Supply Specifications

Power Consumption	190 Watts (nominal)
Output Voltage	0 - 21 VAC
Fiber Receptacle	0.72 (13.3 mm)
Input Voltage	115 VAC / 60 Hz
Temperature Range: Operating	0° to 50°C

ACE[®] Remote Light Source

Dimensions in () are in mm

Product improvements may result in specification or feature changes without notice.

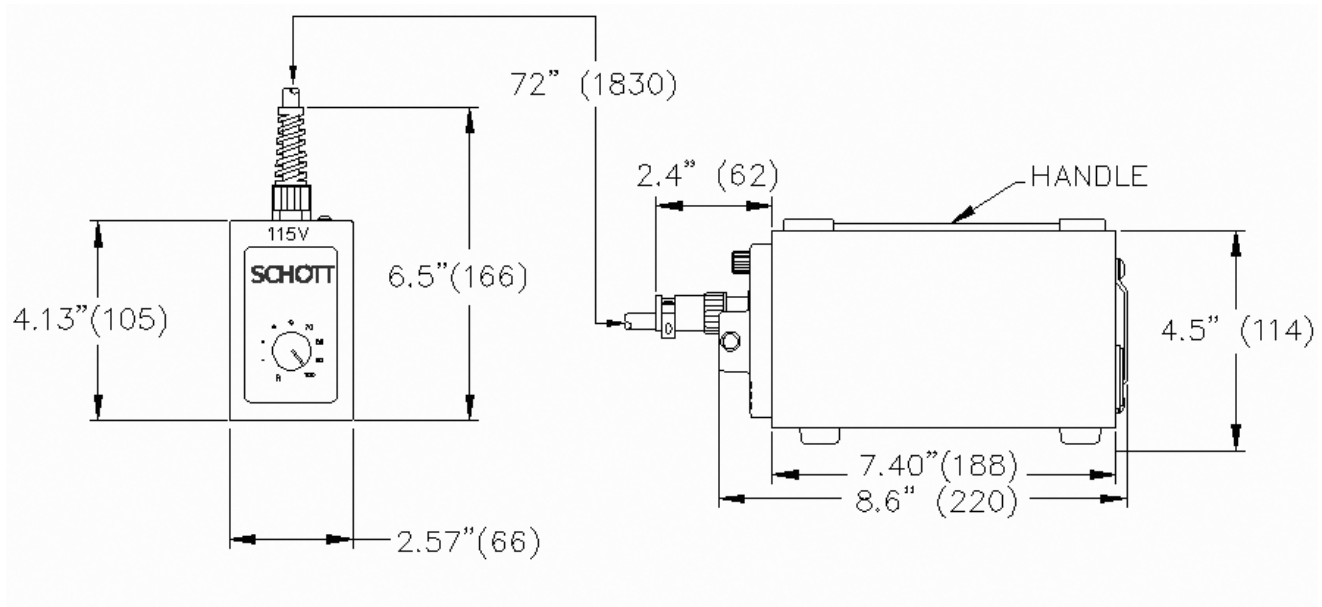
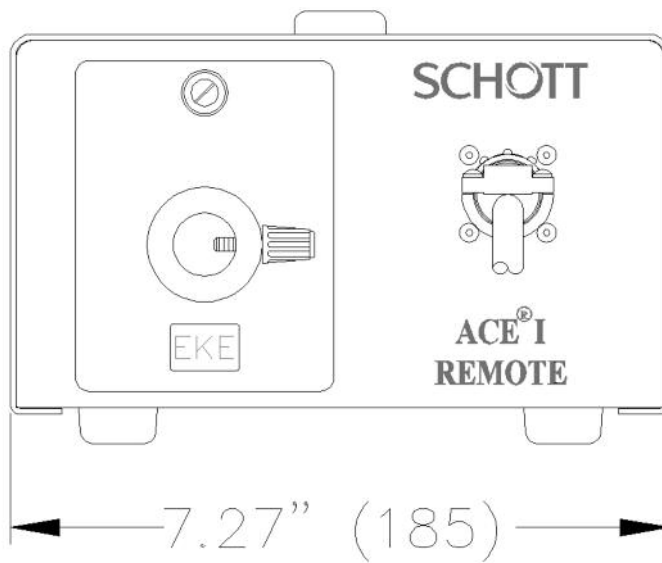

Input: 115 VAC/60 Hz, Output: 0-21 VAC shown with optional EKE modulamp sold separately.

ISLAND OPTICAL SINGAPORE (S) PTE LTD

No.18 Boon Lay Way
#08-121 TradeHub 21
Singapore 139944
Phone: (65) 6515-9110
Fax: (65) 6515-9112
E-mail: islandos@pacific.net.sg
www.islandos.com.sg

SCHOTT
glass made of ideas